



# QuickFlex<sup>®</sup>

Das Schnellwechsel-Werkzeugsystem mit powRgrip<sup>®</sup> für hohe Performance und Präzision.

The quick change system with powRgrip<sup>®</sup> for performance and precision.

**WTO**  
*Higher Productivity*

# powRgrip® Spannzangenadapter powRgrip® collet chuck adapter

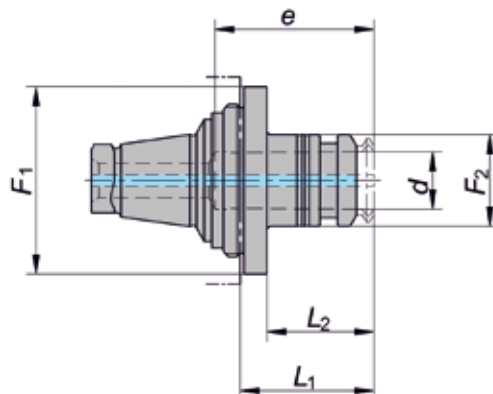

Abmessungen / Dimensions [mm]

Typ/Type	Art.-Nr./Part no.	F1	d min.	d max.	F2	L1	L2
<b>powRgrip® WTO QF-Adapter</b>							
WTO ER-25QF / PGST 15	8040.25150 325225P15*	49	3	10	24	35	28
WTO ER-32QF / PGST 25	8040.32250 325232P25*	58	3	20	40	47	40
WTO ER-40QF / PGST 25	8040.40250 325240P25*	71	3	20	40	48	40

\*WTO Art.-Nr./Part no.



# powRgrip® Spannzangen Typ PGST powRgrip® collets type PGST

Typ/Type	Art.-Nr./Part no.	Ø [mm]
<b>PGST 15 [mm]</b>		
Ø 3,0 mm	1715.03006	3,0
Ø 4,0 mm	1715.04006	4,0
Ø 6,0 mm	1715.06006	6,0
Ø 8,0 mm	1715.08006	8,0
Ø 10,0 mm	1715.10006	10,0

Typ/Type	Art.-Nr./Part no.	Ø [mm]
<b>PGST 25 [mm]</b>		
Ø 3,0 mm	1725.03006	3,0
Ø 4,0 mm	1725.04006	4,0
Ø 6,0 mm	1725.06006	6,0
Ø 8,0 mm	1725.08006	8,0
Ø 10,0 mm	1725.10006	10,0
Ø 12,0 mm	1725.12006	12,0
Ø 16,0 mm	1725.16006	16,0
Ø 20,0 mm	1725.20006	20,0

Typ/Type	Art.-Nr./Part no.	Ø [Zoll/inch]
<b>PGST 15 [inch]</b>		
Ø 1/8"	1715.03186	1/8"
Ø 3/16"	1715.04766	3/16"
Ø 1/4"	1715.06356	1/4"
Ø 5/16"	1715.07946	5/16"
Ø 3/8"	1715.09526	3/8"

Typ/Type	Art.-Nr./Part no.	Ø [Zoll/inch]
<b>PGST 25 [inch]</b>		
Ø 1/8"	1725.03186	1/8"
Ø 3/16"	1725.04766	3/16"
Ø 1/4"	1725.06356	1/4"
Ø 5/16"	1725.07946	5/16"
Ø 3/8"	1725.09526	3/8"
Ø 1/2"	1725.12706	1/2"
Ø 5/8"	1725.15886	5/8"
Ø 3/4"	1725.19056	3/4"

# REGO-FIX powRgrip®

## EINFACH / SIMPLE

Werkzeug per Knopfdruck in 8 Sekunden gespannt  
Tool is clamped in 8 seconds by pushing one single button

## SICHER / SAFE

Keine Hitzeentwicklung – Hohe Spannkraft  
No heat – high clamping force

## powRgrip®

Das Werkzeugspannsystem für heute und morgen  
The tool clamping system of today and tomorrow



Schneidwerkzeug  
Cutting tool



REGO-FIX powRgrip®-Spannzange  
REGO-FIX powRgrip®-collet



QuickFlex®-Adapter für powRgrip®  
QuickFlex® REGO-FIX powRgrip® collet  
chuck adapter

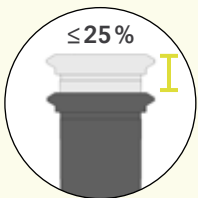

≤ 25 %

PGST ist bis zu 25% kürzer als das konventionelle PG-System. Normschäfte können vollständig eingesteckt werden.

PGST is up to 25% shorter than conventional PG. Norm shafts can be fully inserted.

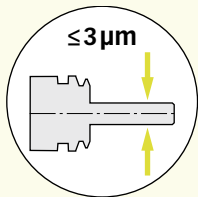

≤ 3 μm

Gesamtsystemrundlauf  
≤ 3 μm bei 3 x D.

Total system runout TIR ≤ 3 μm at 3 x D.

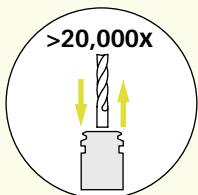

> 20,000x

Höchste Haltekraft und Rundlaufgenauigkeit auch nach 20'000-fachem Werkzeugwechsel.

Maximum clamping force and low runout, even after 20,000 tool changes.

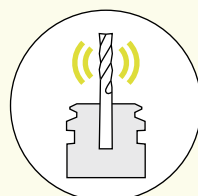

Hervorragende Vibrationsdämpfung.

Excellent vibration dampening.





036200204\_REAG\_WTO\_QuickFlex\_Flyer\_DE\_EN



ADVANCED TECHNOLOGY TOOLS

reich Tools GmbH

Bäckergasse 5, 4707 Schlüssberg

T +43 7248 68 537 F +43 7248 64 285

E office@reich.at W www.reich.at

## REGO-FIX AG

Obermattweg 60  
4456 Tenniken  
Switzerland  
info@rego-fix.com

// REGO-FIX GERMANY  
Lörrach, DE 79539

// REGO-FIX MEXICO  
Queretaro, MX 76903

// REGO-FIX USA  
Whitestown, IN 46075

// REGO-FIX INDIA  
Pune, IN 411038

// REGO-FIX CHINA  
Shanghai, CN 201114

// REGO-FIX MALAYSIA  
Johor Bahru, MA 81100

// REGO-FIX BRAZIL  
18013-280 Sorocaba, SP

// REGO-FIX INDONESIA  
Bojong Gede-Bogor, ID 16923

# REGO-FIX

www.rego-fix.com