

Schrumpffutter Ø3 - Ø4

Schrumpfen Ø3 x 80

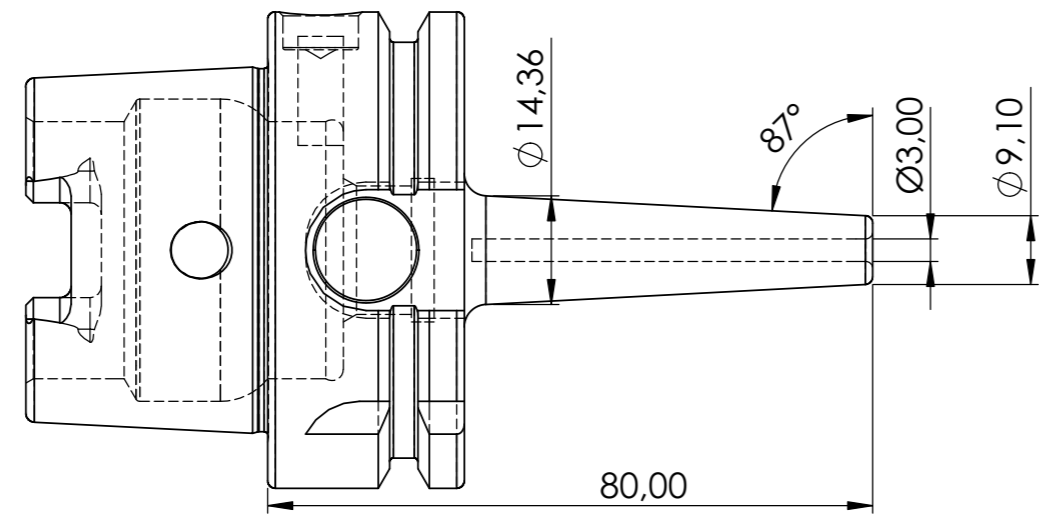

Schrumpfen Ø3 x 120

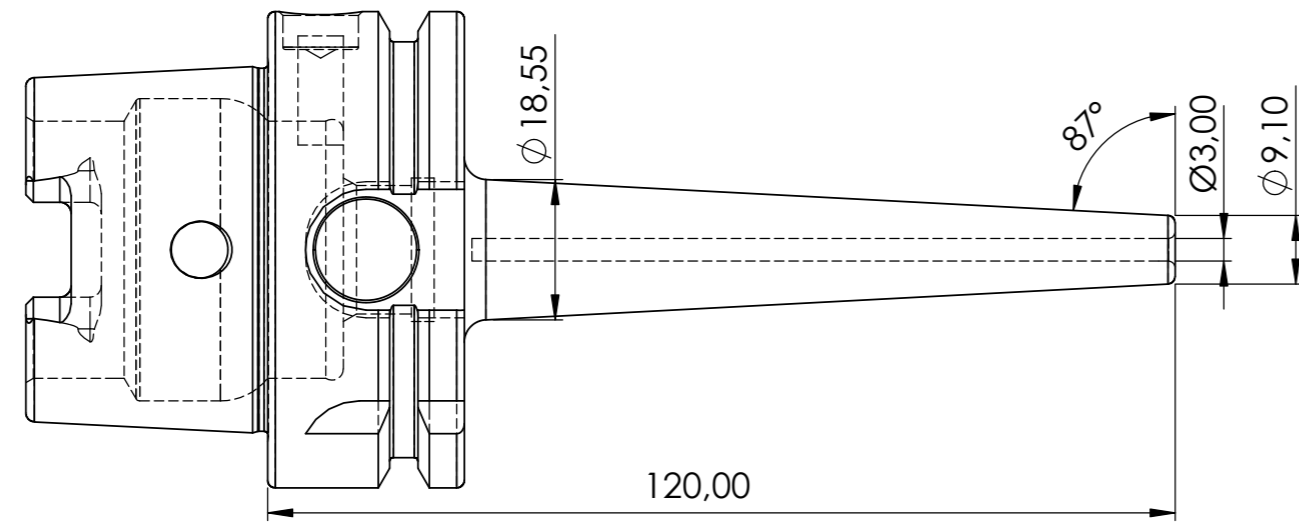

Schrumpfen Ø4 x 80

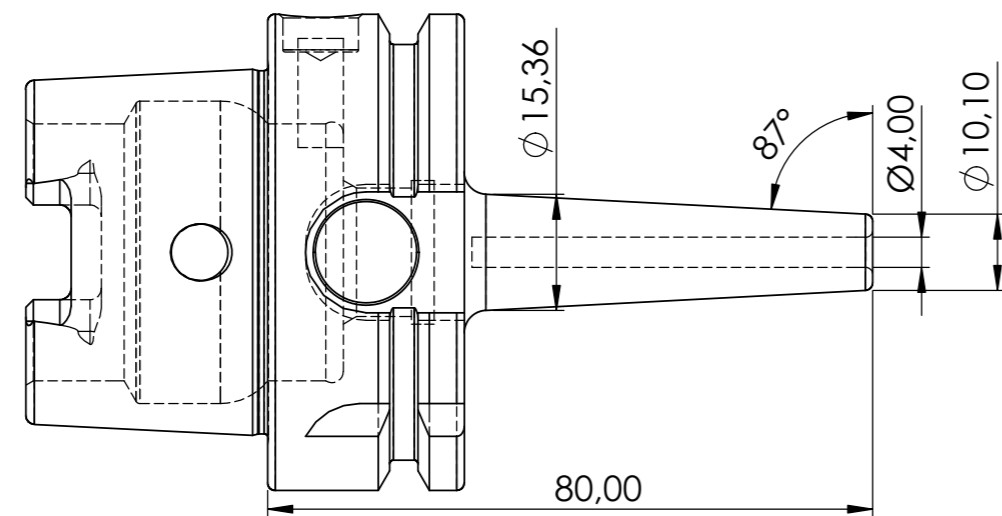

Schrumpfen Ø4 x 160

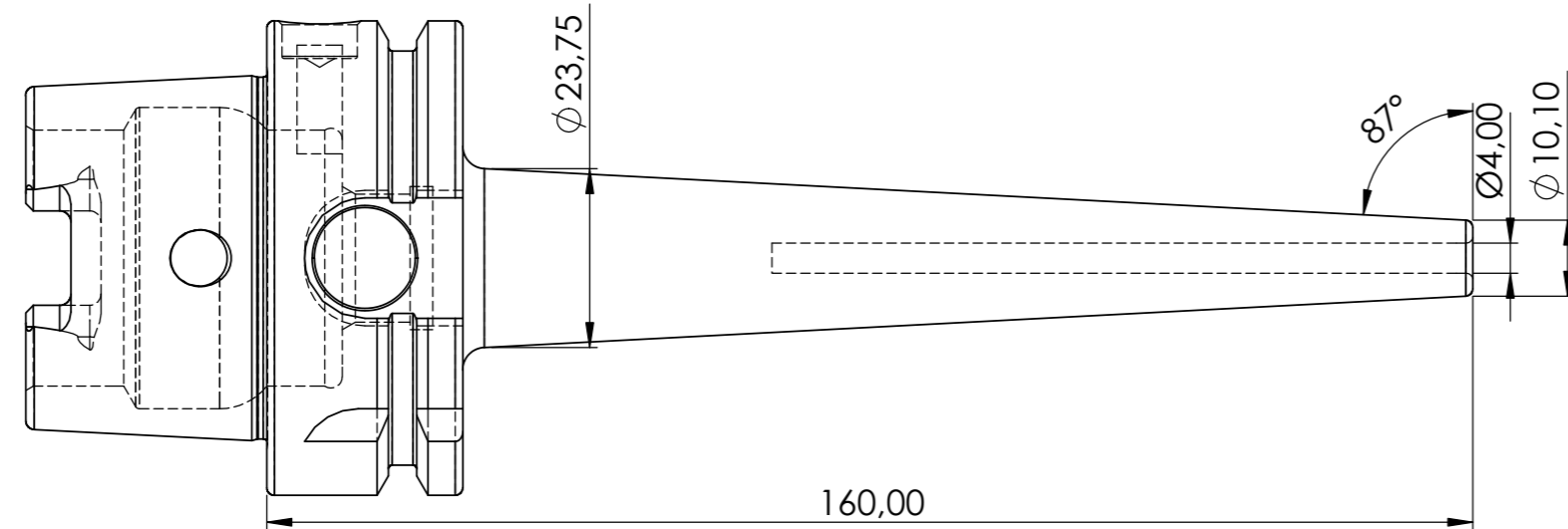

PowRgrip HSK-A 63 "PG6"

PG6 x 80

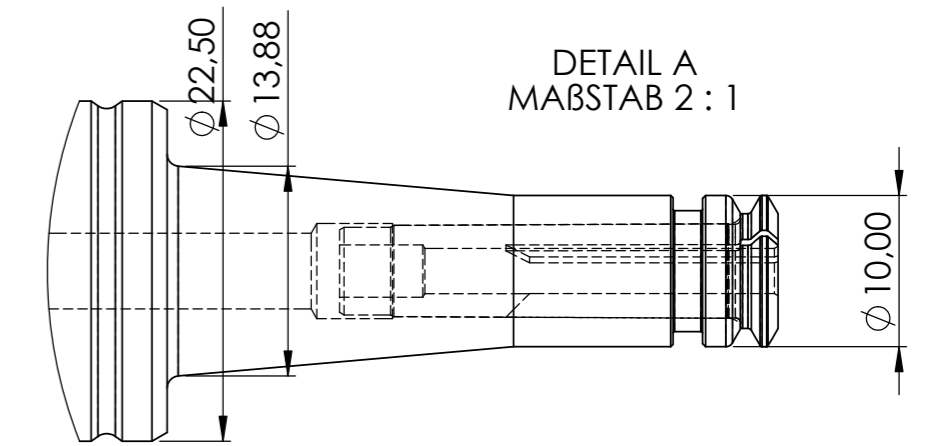
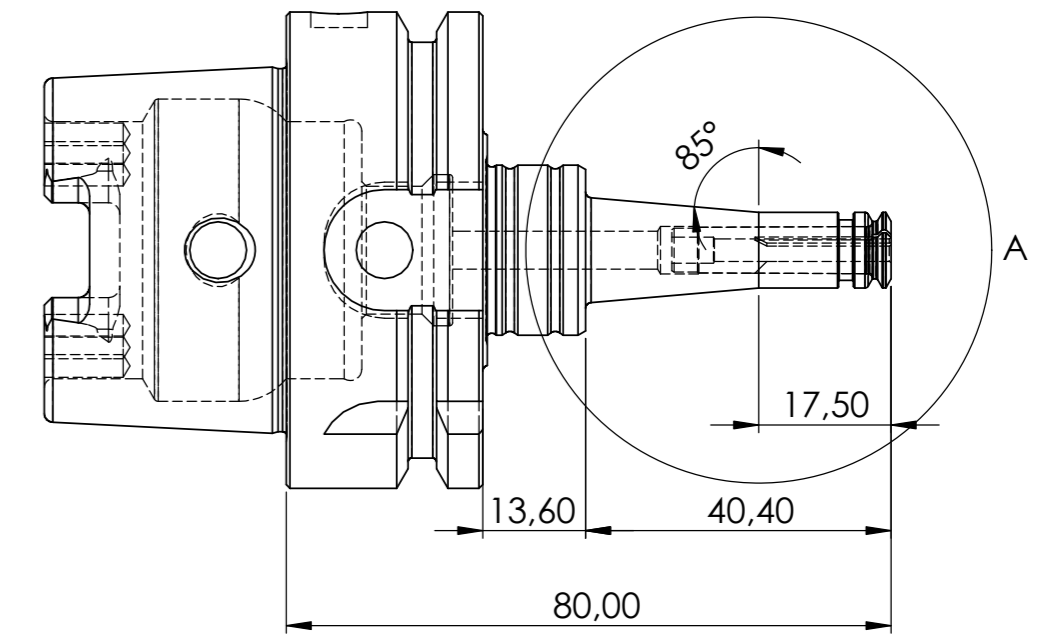

Spannzange PG6 / Ø0,2 - Ø4mm

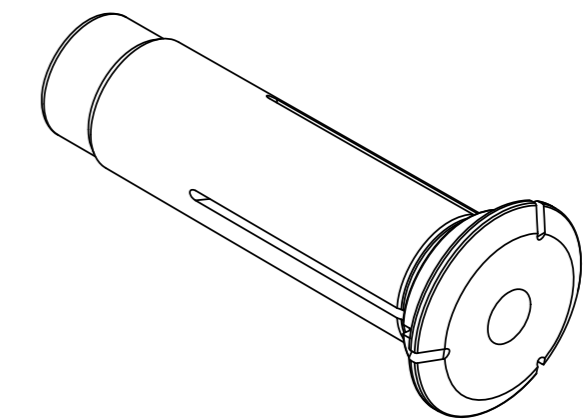

Kunde:		Blatt Format: A2	Maßstab:	Sachnummer:
Kühlung:		 Allgemein- toleranzen: DIN 2768-m	Werkstoff:	Menge:
Beschichtung:			Bezeichnung: HSK63A Vergleich PG6 - Schrumpffutter	
zu bearb. Mat.:				
Zust.	Änderung	Datum	Name	
V1.0		22.08.22	Brandstätter H.	
reich Tool's GmbH, Bäckergasse A-4707 Schlüsselberg				
Ers. für:			Ers. durch:	